

RS485 to SDI-12 Converter

The TBS07 RS485 to SDI-12 Converter is an interface box for connecting a PC, data logger or telemetry unit to one or more sensors with SDI-12 interface. The TBS07 connects to a data logger, telemetry unit or other device with RS485 interface and provides a SDI-12 compliant sensor interface. The TBS07 is a versatile tool for everyone who integrates sensors and data recorders or who installs, tests or maintains SDI-12 based data acquisition systems.



Features

- RS485 to SDI-12 converter
- Transfer Mode
- Plug and play
- No driver required
- Baud Rate: 38400, 19200, 9600, 4800 Baud, user configurable
- Half- and Full duplex
- 6V ... 15V supply voltage
- Low power mode
- Screw terminal blocks

- DIN-rail housing or IP67 Fibox housing
- Operating Temperature Range:
- 40°C ... + 85°C

Target Applications

- SDI-12 Data Recording
- SDI-12 Field Installations
- SDI-12 Interface Debugging
- SDI-12 Sensor Testing

RS485 to SDI-12 Converter

Contents

1	INTRODUCTION	3
1.1	PRODUCT FEATURES	3
2	APPLICATION	4
3	CONFIGURATION	5
4	FUNCTIONAL DESCRIPTION	6
4.1	OVERVIEW	6
4.2	INTERFACE WITH DATA LOGGER OR TELEMETRY UNIT	6
5	HARDWARE DESCRIPTION	7
5.1	CONNECTIONS OVERVIEW	7
5.2	CONNECTIONS	9
5.3	POWER SUPPLY	10
6	SDI-12 BASICS	10
7	ORDERING INFORMATION	11
8	HISTORY	11

Figures

Figure 1 –TBS07 Application, standard setup for controlling / testing sensors	4
Figure 2 –default jumper settings	5
Figure 3 –TBS07 basic application setup	7
Figure 4 –Connections	8

RS485 to SDI-12 Converter

1 Introduction

SDI-12 is a standard for interfacing data recorders with microprocessor-based sensors. SDI-12 stands for serial/digital interface at 1200 baud. It can connect multiple sensors with a single data recorder on one cable. It supports up to 60 meter cable between a sensor and a data logger.

The SDI-12 standard is prepared by

**SDI-12 Support Group
(Technical Committee)
165 East 500 South
River Heights, Utah
435-752-4200
435-752-1691 (FAX)
<http://www.sdi-12.org>**

The latest standard is version V1.3 and dates from July 18th, 2005. The standard is available on the web site of the SDI-12 Support Group.

The TBS07 implements all functions for interfacing SDI-12 sensors to a RTU, data logger or PC with an RS485 interface.

It is a plug and play solution for controlling or testing of sensors with SDI-12 interface.

1.1 Product Features

- RS485 to SDI-12 Interface based on TBS01 SDI-12 module
- Transfer Mode
- Plug and play
- No driver required
- Baud rate: 38400, 19200, 9600, 4800 Baud, user configurable
- Half- or full duplex, user configurable
- Termination, user configurable
- 6 to 15V supply voltage
- DIN-Rail or IP67 FIBOX housing
- Operating Temperature Range: - 40°C ... + 85°C

RS485 to SDI-12 Converter

2 Application

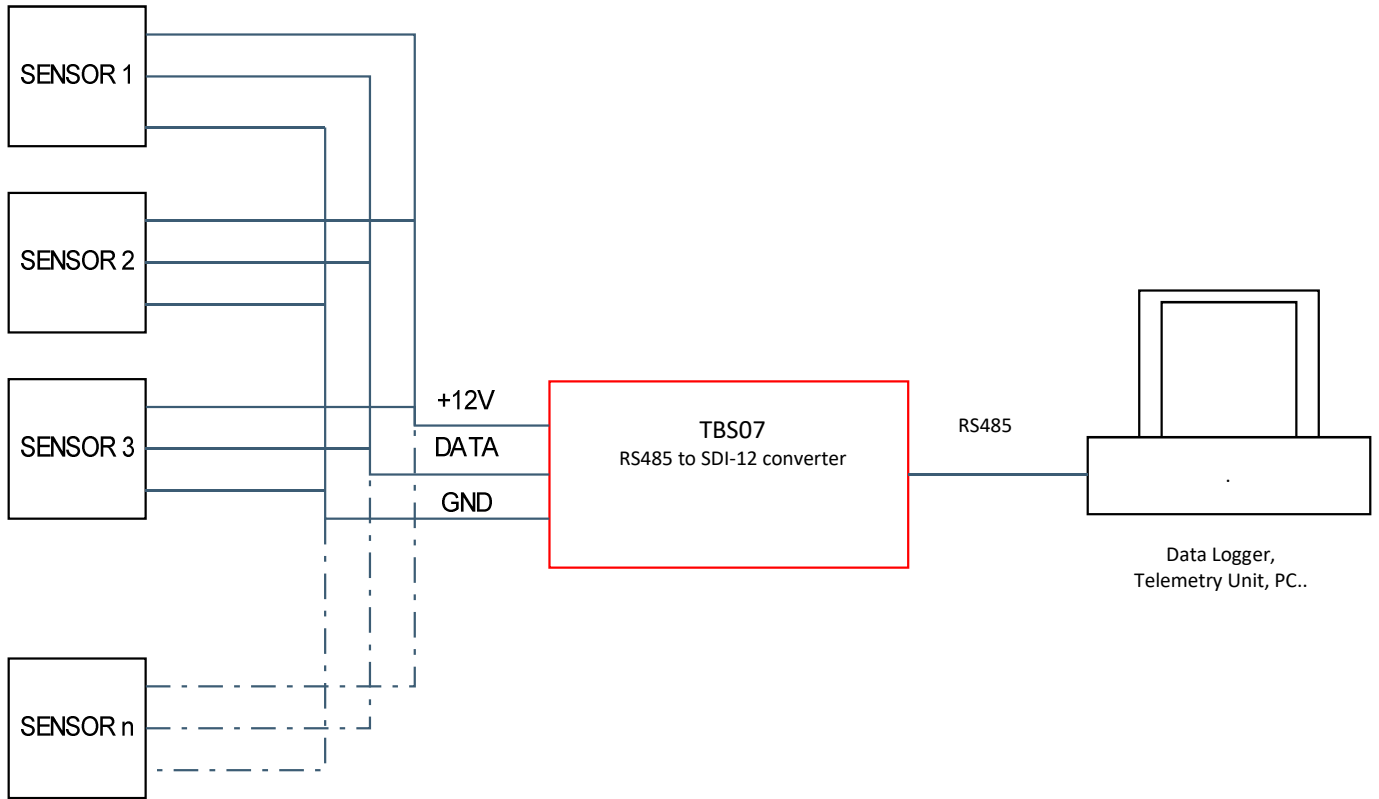

Figure 1 –TBS07 Application, standard setup for controlling / testing sensors

RS485 to SDI-12 Converter

3 Configuration

The TBS07 is factory configured to full duplex, 19200 Baud and no termination.

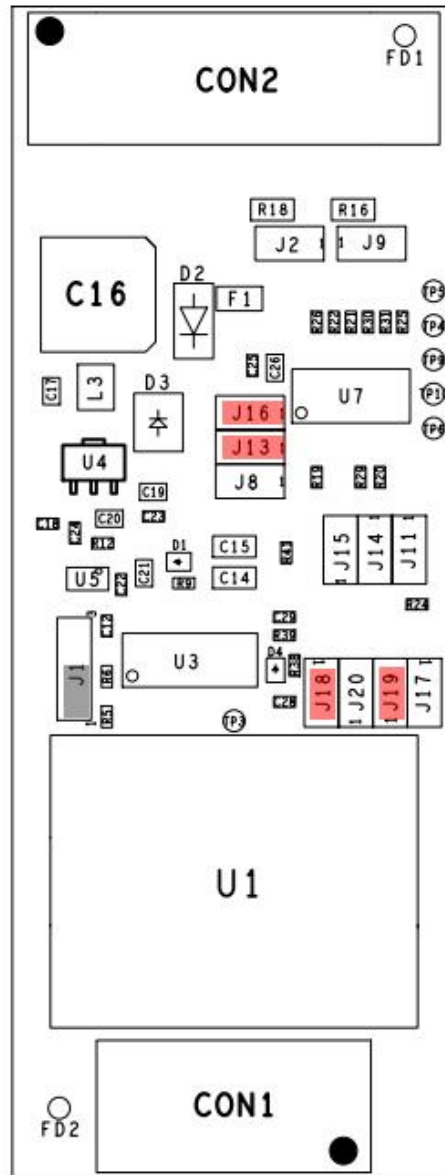

Figure 2 –default jumper settings

In order to change the settings, remove the bottom of the DIN-rail housing to get access to the PCBA. Refer to the tables below to change baud rate, termination or duplex mode.

The same jumper settings apply to the Fibox variant.

RS485 to SDI-12 Converter

BAUD RATE	
4800 Baud	set jumpers J17, J18
9600 Baud	set jumpers J17, J20
19200 Baud	set jumpers J19, J18
38400 Baud	set jumpers J19, J20

DUPLEX MODE	
FULL DUPLEX	set jumpers J16, J13
HALF DUPLEX	set jumpers J16, J13, J8

For half duplex operation connect to TX+ and TX-

Termination	
120 OHM RX Termination	set jumper J9
120 OHM TX Termination	set jumper J2

Jumper 1 (Power management):

Jumper 1-2: Always On (6 mA); default factory setting

Jumper 2-3: Power saving mode (>250uA), TBS07 will wakeup automatically when data is present at the Rx pin, and switches into sleep mode 2.5 seconds after RX becomes idle. Because it using data to wakeup, so user need send 1 byte dummy before send real data.

4 Functional Description

4.1 Overview

The SDI-12 standard defines a set of commands to configure sensors and to initiate measurements. Upon receiving specific commands, the sensor may carry out internal tasks, respond with information on conversion time or send measurement data.

SDI-12 commands typically are ASCII strings generated by the data recorder/controller firmware. TBS07 can be controlled by a PC application or hyper terminal and converts the command strings to the logic levels and baud rate specified by the SDI-12 standard. Furthermore TBS07 handles breaks, marks and all other details of the SDI-12 protocol.

Upon receiving data or status information originated by a Sensor, TBS07 extracts the corresponding ASCII strings and sends it to COM Port of the PC.

4.2 Interface with data logger or telemetry unit

RS485 to SDI-12 Converter



Figure 3 –TBS07 basic application setup

The setup requires a data logger or telemetry unit with RS485 interface capable of handling ASCII strings representing SDI-12 commands. The TBS07 receives commands from the RS485 Interface (e.g. via data logger, RTU or PC), and transfers the commands to the SDI Interface, waits for sensor response and transfers the response (measurement results, etc.) back to the RS485 Interface of the data logger, RTU or PC. All SDI-12 commands are supported. It transparently forwards SDI-12 commands and sensor response in ASCII between a master with RS485 interface and sensor(s) with SDI-12 interface. It takes care of all SDI-12 standard related protocol and electrical requirements.

5 Hardware Description

5.1 Connections overview

RS485 to SDI-12 Converter

RS485 Side, from left to right:

- TX+ output
- TX- output
- RX+ input
- RX- input
- Ground
- 6V to 15V external supply voltage



SDI-12 Side, from left to right:

- Cable shield
- Ground
- SDI-12 Data line
- SDI-12 Supply voltage

Figure 4 –Connections

RS485 to SDI-12 Converter

5.2 Connections

TBS07 supports RS485 with 38200, 19200, 9600, 4800 Baud.

Factory default is 19200 Baud, full duplex, no termination.

Other communication settings:

- 8 Bits
- No Parity
- 1 Stop Bit
- No Handshake

4 Pin terminal block:

CON1 – SDI-12 Interface

Shield: connect to the shield of the SDI-12 cable or leave it unconnected

Ground: connect to the GND wire of the SDI-12 cable

SDI-12 data: connect to the data wire of the SDI-12 cable

SDI-12 Power: connect to the positive supply voltage wire of the SDI-12 cable; the SDI-12 supply voltage is directly connected to the RS485 supply line. SDI-12 Power is derived from the +12V supply terminal. It reversed voltage protected and fused (100mA, slow)

6 Pin terminal block:

CON2 – Power supply & RS485 interface

Full Duplex

TX+, connect to RX+ of the data logger or telemetry unit

TX-, connect to RX- of the data logger or telemetry unit

RX+, connect to TX+ of the data logger or telemetry unit

RX-, connect to RX- of the data logger or telemetry unit

Half Duplex

TX+, connect to TX+ of the data logger or telemetry unit

TX-, connect to TX- of the data logger or telemetry unit

Ground: connect to the GND of supply for TBS07 DR

+12V: connect to an external power supply (7V...12V)

Shield and grounds are internally connected together

RS485 to SDI-12 Converter

5.3 Power Supply

The TBS07 can operate from a single 6V -15V supply and has a supply output for SDI-12 sensors. The SDI-12 supply voltage is directly derived from the 6V-15V supply voltage, fused (100mA) and transient and reverse voltage protected.

6 SDI-12 Basics

SDI-12 is a serial data communication standard for interfacing multiple sensors with a data recorder

SDI-12 uses a shared bus with 3 wires: power (12V), data, ground

Data rate: 1200 baud

Each sensor at the bus gets a unique address which is in the range ASCII [0-9, a-z, A-Z]. The default address of every sensor is ASCII[0]. When setting up a SDI-12 sensor network, every sensor needs to be configured with a unique address. This can be done using the Change Address Command.

A sensor typically can measure one or more parameters.

Sensor manufacturers usually specify Extended Commands to configure or calibrate sensors. These commands are specified by the manufacturer, but they follow the command structure specified by SDI-12.

A typical recorder/sensor measurement sequence proceeds as follows:

- 1) The data recorder wakes all sensors on the SDI-12 bus with a break.
- 2) The recorder transmits a command to a specific, addressed sensor, instructing it to make a measurement.
- 3) The addressed sensor responds within 15.0 milliseconds returning the maximum time until the measurement data will be ready and the number of data values it will return.
- 4) If the measurement is immediately available, the recorder transmits a command to the sensor instructing it to return the measurement result(s). If the measurement is not ready, the data recorder waits for the sensor to send a request to the recorder, which indicates that the data are ready. The recorder then transmits a command to get the data.
- 5) The sensor responds, returning one or more measurement results

SDI-12 command structure:

Each SDI-12 command is an ASCII string with up to 5 characters, starting with the sensor address and terminated by a ! character.

Example:

Send Identification Command **0!**

0 is the sensor address (sensor zero). Upon receiving this command, the sensor will send an ASCII string containing sensor address, SDI-12 compatibility number, company name, sensor model number, sensor version number and sensor serial number.

The standard process to carry out a measurement is to send a measurement request upon which the sensor responds with the time that is required to carry out the measurement and the number of data items being returned. After waiting the time that the sensor requires to carry out the measurement, the data recorder sends a Read Command to get the measurement results.

Example:

Start Measurement Command **0M1!**

Sensor 0 might respond **00302** which means the measurement will take 30 seconds and deliver 2 values.

After min. 30 seconds, the data recorder can send the Read Data Command **0D0!** to which Sensor 0 might reply **0+27+1050**. +27+1050 is the two measurement results which may be 27°C and 1050 millibar.

RS485 to SDI-12 Converter

The response string of a sensor is always in ASCII format and may contain up to 40 or up to 80 characters, depending on the type of command. Out of 40 or 80 characters, the values part of the response string may contain up to 35 or 75 characters.

Important: Every SDI12 command ASCII string sent from the RS485 master needs to be terminated with Carriage Return, Line Feed.

7 Ordering Information

Part Number	Description
TBS07	RS485 to SDI-12 Converter, IP67 FIBOX housing PC081206
TBS07 DR	RS485 to SDI-12 Converter, DIN-Rail housing

8 History

Version	Date	Author	Changes
V1.0	7.3.2014	Mayerhofer	Creation
V1.1	18.4.2014	Mayerhofer	Update of Chapter 5.2
V1.2	04.07.2014	Mayerhofer	Update of full/half duplex jumper table
V1.3	05.09.2014	Mayerhofer	Update of chapter 7
V1.4	24.10.2014	Mayerhofer	Correction of chapter 3, half duplex connectivity
V1.5	22.01.2015	Mayerhofer	Updated chapter 5.2
V1.6	02.04.2016	Mayerhofer	Updated chapter 6
V1.7	01.11.2018	Npthin	Jumper 1 (Power management)